

*ZED X One

Camera and SDK Overview

The ZED X One is the ideal choice for flexible integration and customization of stereo systems or for multiple-camera surround vision. It is especially well-adapted for large machines.

The ZED X One offers two sensor options: 2.3 MP Global Shutter and 4K Sony Starvis 2, making it ideal for robots deployed in low-light conditions in various sectors including agriculture, logistics or construction.

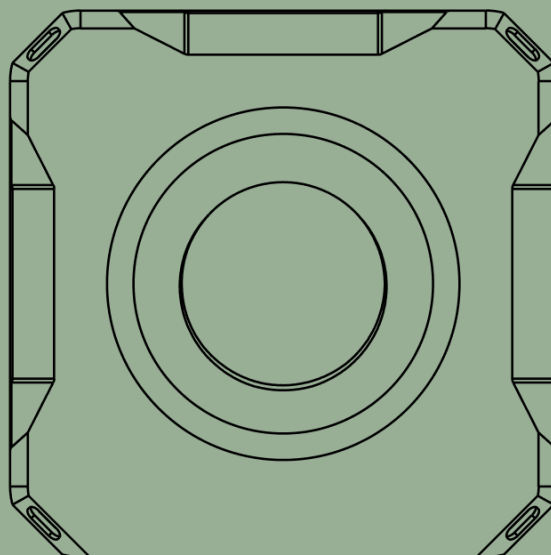

*ZED X One General Specifications

Global or Rolling Shutter

Choose the best sensor for your application. Capture distortion-free images of lightning-fast action with our global shutter sensor or benefit from ultra-high resolution even in low-light conditions with our rolling shutter sensor.

Secure GMSL2 Connection

GMSL2 connectivity is ideal for robotics. Transmit video without EMI and high data rate through a lockable interface to a Jetson Orin over a distance of up to 15M with low latency.

Multi-camera synchronization

Hardware synchronization for multiple connected cameras at frame-level within 15 microseconds. Capture RGB and depth images of the same scene with multiple cameras all triggered at the same time.

Low-level camera control

Benefit from low-level control to finely tune image parameters and achieve unparalleled image quality and customization in camera firmware development.

High-performance IMU

The all-new IMU combines a 16-bit triaxial accelerometer and gyroscope with vibration resistance, ultra low noise and bias for exceptional motion tracking

Multiple S-mount lens options

Benefit from multiple lens options to create the best camera system for your application.

*ZED X One Lens Options

Global Shutter

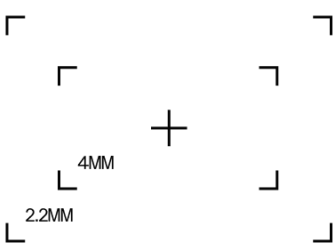

Wide

2.2mm fixed focal lens offers an exceptionally wide field of view while also providing optically corrected distortion for enhanced image quality.

Narrow

The 4mm focal length lens is perfect for an enhanced resolution and depth accuracy at longer ranges.

4K Sony Starvis 2



Wide

3.05mm fixed focal lens offers an exceptionally wide field of view while ensuring distortion correction and optimal light sensibility, resulting in superior image quality.

*ZED X One General Specifications

ZED X ONE

Camera Model	ZED X ONE GS			ZED X ONE 4K	
Sensor	Onsemi AR0234			Sony IMX678	
Size	1/2.6"			1/1.8"	
Resolution	1928 (H) x 1200 (V)			3856 (H) x 2180 (V)	
Pixel size	3µm x 3µm			2µm x 2µm	
Shutter sync	Global Shutter			Rolling Shutter	
Lens Options	None	Wide	Narrow	None	Wide
Focal Length	-	2.2mm	4mm	-	3.1mm
FOV	-	120.8°(D) 110°(H) 79.6°(V)	91°(D) 80°(H) 52°(V)	-	118.8°(D) 109.9°(H) 71.8°(V)
Lens Mount	S-Mount				
Motion Sensor	200Hz / 400Hz 16-bits Accelerometer (up to 12g)				
Connector	Serial Coax GMSL2 connector - FAKRA Z				
Operating Temp	-20°C to +55°C (-4°F to 131°F)				
Power	Power via GMSL2 (PoC)				
Mounting option	4x M4 (bottom) + 1/4"-20UNC adapter plate				
Dimensions	31mm x 31mm x 38.6mm	31mm x 31mm x 52.7mm	31mm x 31mm x 52mm	31mm x 31mm x 38.6mm	31mm x 31mm x 58.1mm
Weight	48g	55g	50g	48g	59g
Part number	ZED-411010	ZED-412010	ZED-413010	ZED-421010	ZED-422010
Warranty	2-year hardware warranty				

*ZED X One Sensor Stack Specifications

The IMX678 SONY Starvis 2 sensor offers excellent low-light performance and cutting-edge HDR technology for unparalleled clarity and detail in high-resolution video recording.

IMX678 SONY Starvis 2 Technology

Sensor Type	1/1.8" 8.4MP CMOS
Array Size	3856 x 2180 pixels
Pixel Size	2µm x 2µm
Shutter	Rolling Shutter
Output Resolution	3840x2160 @15ps 1920x1080 @60fps binning mode 1920x1200 @60fps cropping mode
Output Format	RAW12 (v4l2) / NV21 (Argus)
Max S/N Ratio	>=40dB
Dynamic Range	85dB
Sensitivity	15886 Digit/lux/s

Exceptional low-light capabilities and high sensitivity



Conventional Front-illuminated image sensor



Sensor with STARVIS technology
Back-illuminated image sensor

The AR0234 sensor delivers 2.3MP clarity and great low-light capabilities, ideal for capturing crisp and distortion-free footage of fast moving objects in robotics applications.

ONSEMI AR0234

Sensor Type	1/2.6" 2.3MP CMOS
Array Size	1928 x 1208 pixels
Pixel Size	3µm x 3µm
Shutter	Electronical synchronized global shutter
Output Resolution	1920x1200 @60fps 1920x1080 @60fps cropping mode 960x600 @120fps binning mode
Output Format	RAW10 (v4l2) / NV21 (Argus)
Max S/N Ratio	38dB
Dynamic Range	71.4dB
Sensitivity	22.3Ke/Lux*s

Distortion free images of fast moving objects

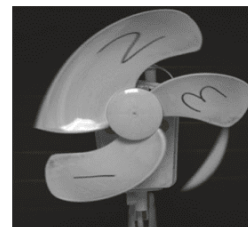

Rolling Shutter

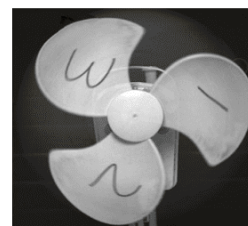

Global Shutter

*ZED X One Sensor Stack Specifications

Motion Sensors

Accelerometer Range	+/- 12G
Accelerometer Resolution	0.36 mg
Accelerometer Noise Density	3.2 mg
Gyroscope Range	+/- 1000 dps
Gyroscope Resolution	0.03 dps
Gyroscope Noise Density	0.10 dps
Sensitivity Error	+/- 0.5%
Output Data Rate	400 Hz

System Requirements

System	NVIDIA Jetson AGX Orin NVIDIA Jetson AGX Xavier NVIDIA Jetson Orin NX, Xavier NX
OS	Jetson Linux (L4T) v35.1 or newer

Sensors API

You can access these sensors and acquire sensor data by using the Sensors API.

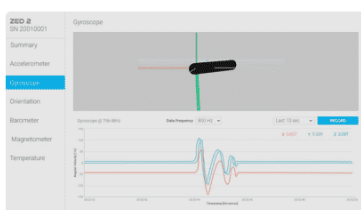

*ZED X One Accessories

FAKRA Z Cable

A wide range of camera cables are readily available, tailored to diverse requirements and applications, offered in varying lengths to suit both compact and expansive setups.

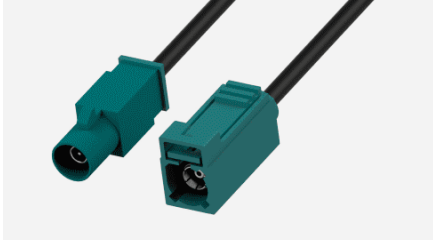

Male to Female

1.5m (4.93ft)	CBL-310100
5m (16.4ft)	CBL-310200
10m (32.8ft)	CBL-310300

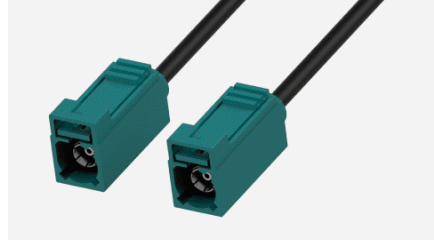

Female to Female

0.3m (0.98ft)	CBL-320100
1.5m (4.93ft)	CBL-320200
5m (16.4ft)	CBL-320300
10m (32.8ft)	CBL-320400

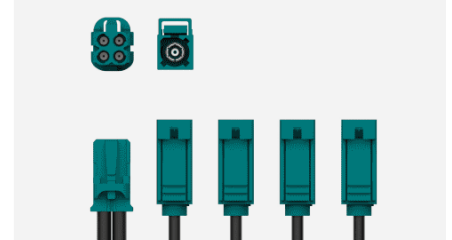

Female to Female - 1-to-4

0.5m (1.64ft)	X
---------------	---

ZED Link Mono Capture Card

To capture the ZED X on the NVIDIA Jetson AGX platform, one solution is to utilize a GMSL2 capture card that directly connects to the Jetson's CSI port.



Compatibility	NVIDIA Jetson Xavier/Orin Platform
Max. number of cameras	1
Deserializer	MAX9296
Bandwidth	Up to 6Gb/s total bandwidth
Power	Requires external power (9V - 19V)

ZED Box Orin NX

The ZED Box, equipped with the latest NVIDIA Jetson Orin NX, serves as a robust AI gateway for autonomous robotics and advanced video analytics.



AI Performance	16GB - 100 TOPS / 8GB - 70 TOPS
Compatible camera	ZED 2i Stereo Camera, ZED X Stereo Camera
I/Os	3x USB 3.2 Gen2 (10 Gbps) 1x Micro USB OTG (Flash) 1x Gigabit Ethernet 1x HDMI, 4x Gigabit Multimedia Serial Links (GMSL2)** 1x WiFi 6 connectivity** 1x RTK GNSS GPS Ublox ZED F9P**

*ZED X One Accessories

ZED Link Dual Capture Card

To capture the ZED X on the NVIDIA Jetson AGX platform, one solution is to utilize a DUAL GMSL2 capture card that directly connects to the Jetson's CSI port.

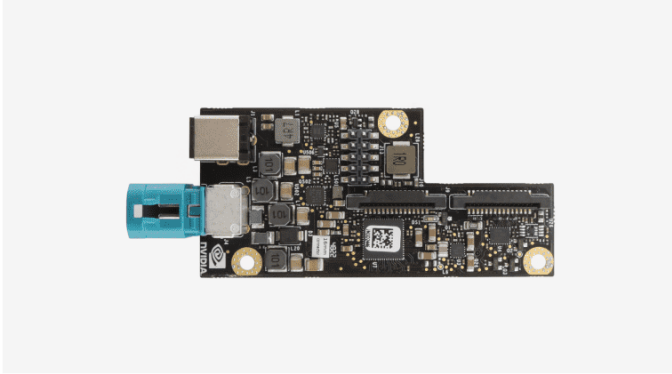

Compatibility	NVIDIA Jetson Xavier/Orin Platform
Max. number of cameras	2
Deserializer	MAX96712
Power	Via Samtec CSI port of the Jetson AGX External required when using MIPI ports

ZED Link Quad Capture Card

To capture the ZED X on the NVIDIA Jetson AGX platform, one solution is to utilize a QUAD GMSL2 capture card that directly connects to the Jetson's CSI port.



Compatibility	NVIDIA Jetson Xavier/Orin Platform
Max. number of cameras	4
Deserializer	2 x MAX96712
Power	Requires external power (9V - 19V)

Dual Camera Mount for ZED X One

This rigid aluminum mount allows you to mount two cameras on a tripod. Adjust the stereo baseline of your ZED X One and capture depth from 5cm to 100m.



Dimensions	310 x 28 x 6 mm (12.2 x 1.1 x 0.24 inch)
Mounting	Mount on any surface using M4 screws or on any tripod using 1/4" screws.
Cameras Separation Range	Minimum camera separation: 52mm. Maximum camera separation: 222mm.

*ZED X One Technical Drawings

ZED X One

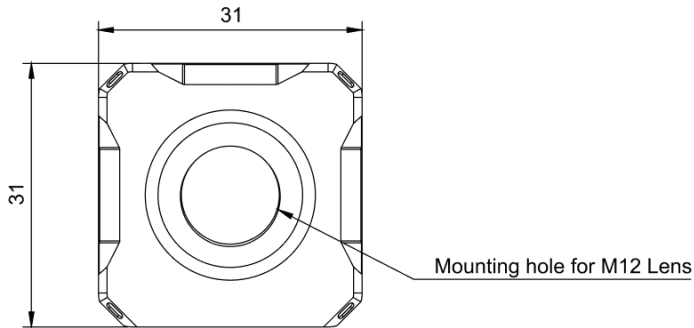

ZED XOne GS WIDE

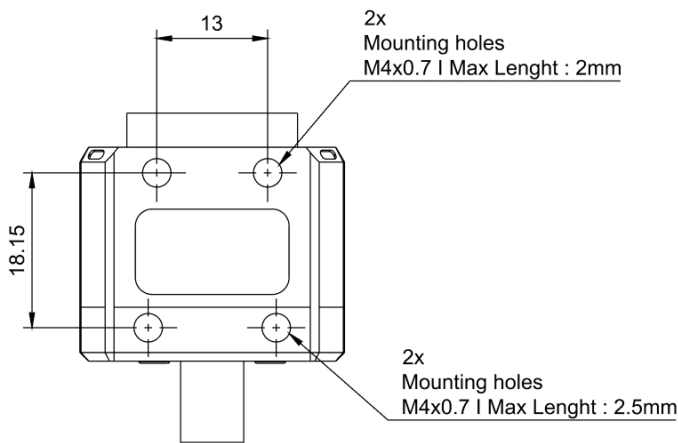
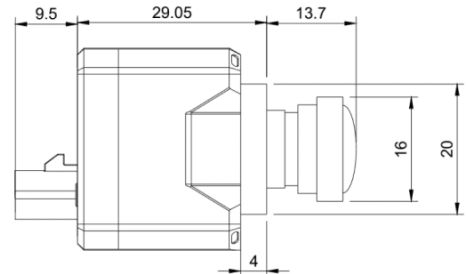

ZED XOne GS NARROW

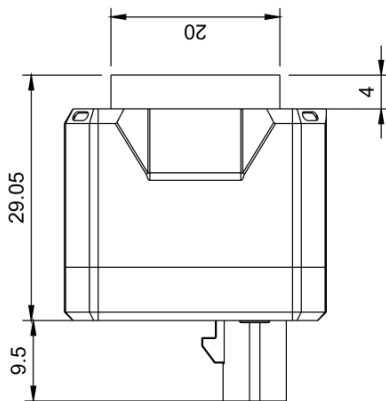
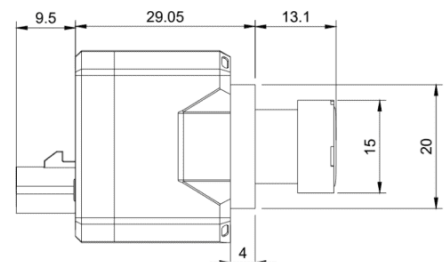

ZED XOne 4K WIDE

